

**UME-03 Investigating New-**

**Newton's second Law of Motion**

A trolley experiences an acceleration when an external force is applied to it. The aim of this data logging experiment is explore the relationship between the magnitudes of the external force and the resulting acceleration.

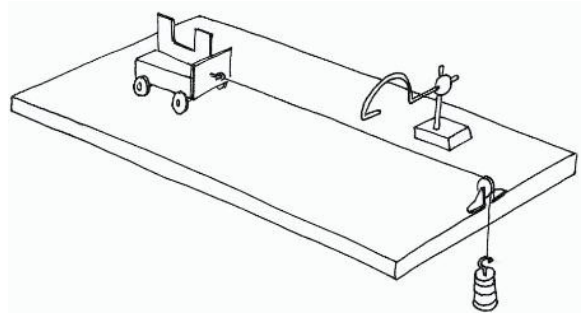

**UME-03 Investigation of Newton's second law .consists of:**

<b>Item</b>	<b>Description</b>	<b>Qty</b>
	<i>Dynamics trolley</i>	3
	<i>Pulley and string</i>	1
	<i>Slotted masses, 400 g</i>	3
	<i>Mass, 1 kg</i>	1
	<i>Clamp</i>	1
	Light Gate	4
	Counter	1
	Option	
	Computer interface	1